



BEEHIVE RSTD06 SEPARATOR

Powerful combination of versatility, durability and reliability

The Beehive® RSTD06 brings solid design and unmatched durability to any production line.

The Beehive® RSTD06 is widely recognized as one of the most versatile separators in the industry. Its unique ability to handle a broad range of raw products that other separators cannot handle, puts it in a class by itself. Its precise controls allow the operator to generate a variety of textures, resulting in extraordinary "bite", with the capability to produce the best texture and a premium end product. With heavy-duty construction, low maintenance costs, a well-established track record of reliability and satisfied customers in over 50 countries worldwide.



BEEHIVE® RSTD06

Innovative Engineering for your heavy duty applications

Rugged, stainless steel construction, hygienic design, tapered chamber technology, and a powerful feeding mechanism allows the Beehive® RSTD06 to successfully tackle the most challenging application. In addition, the RSTD06's patented Auto-Cam® technology sets the auger to chamber clearance precisely, insuring consistent product quality and extending part life.

APPLICATIONS:

- Deboning
- Desinewing
- Defatting
- Separation

RAW MATERIAL:

- Pork
- Chicken
- Beef
- Turkey
- Fish
- Mutton
- Fruits/Vegetables

BEEHIVE – EXPERTS IN SEPARATION



BEEHIVE® RSTD06

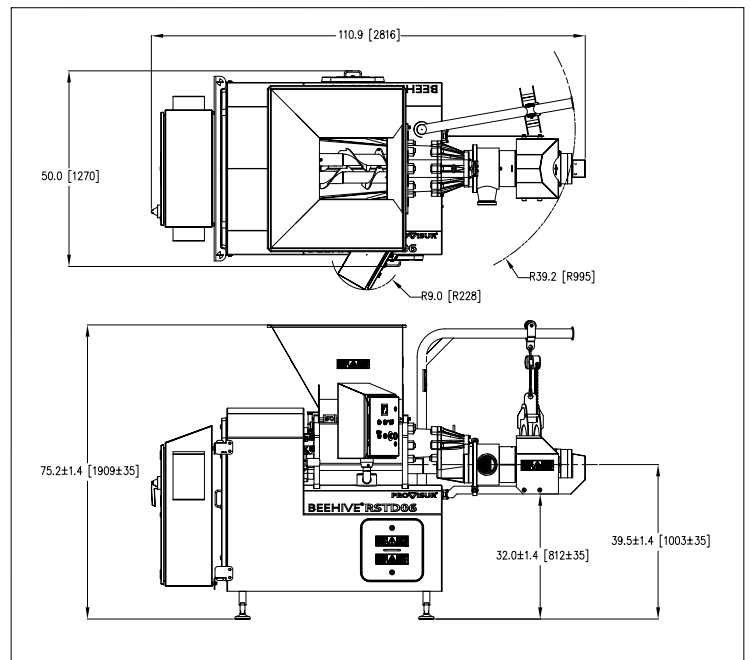

SPECIFICATIONS:

	RSTD06 STD	RSTD06 MAX
Input Capacity (varies with product)	4000–8000 lbs/h (1800–3630 kg/h)	8000–15000 lbs/h (3630–6800 kg/h)
Total power	55HP (41 kW)	70HP (52 kW)
Hopper capacity	10 cu.ft. (292 l)	10 cu.ft. (292 l)
Feed-screw/Pump Speed (variable)	26–79 RPM	33–98 RPM
Auger Speed (constant)	227 RPM	321 RPM
Machine Dimensions L x W x H	111 x 50 x 75 inch (2820 x 1270 x 1910 mm)	111 x 50 x 75 inch (2820 x 1270 x 1910 mm)
Machine weight uncrated	approx. 4000 lbs. (1800 kg)	approx. 4000 lbs. (1800 kg)
Machine weight crated	approx. 4500 lbs (2050 kg)	approx. 4500 lbs (2050 kg)