



Highest Throughput
Superior Product Quality
Weiler Expertise
Patented Dominator Technology

Weiler® Dominator® 16XP

Improve product quality and throughput

Designed for efficiency and performance, the Weiler Dominator 16XP is the latest innovation in high-throughput grinding. Engineered to handle pre-broken frozen meats with ease, this powerful grinder increases productivity while reducing operational complexity. By replacing the need for multiple smaller grinders, the Dominator 16XP optimizes floor space, reduces maintenance costs, and enhances overall workflow efficiency.

- Higher throughput, greater efficiency – Processes up to 660 lbs./minute, improving production speed.
- Space-saving design – Eliminates the need for multiple grinders, freeing up valuable floor space.
- Lower cost of ownership – Reduces maintenance and operational expenses by consolidating equipment.
- Built for reliability – Durable stainless steel construction ensures longevity in high-demand environments.



PROVISUR[®]
TECHNOLOGIES

Features

Dominator® Grinding Technology

Utilizes a balanced flow design to ensure efficient product movement to the grind plate, eliminating rollback and minimizing turbulence. This results in consistent particle definition and superior product quality.

Polished Food Contact Surfaces

Incorporates polished surfaces in contact with food to prevent fat separation and product buildup, leading to reduced waste and easier sanitation.

Robust Stainless Steel Construction

Built with durable stainless steel, the grinder is designed to handle the toughest raw materials, ensuring longevity and reliable performance in demanding environments.

Simplified Maintenance with Fewer Parts

Designed with fewer parts and self-aligning components, the Dominator technology simplifies operation, maintenance, and sanitation, leading to lower total operating costs.

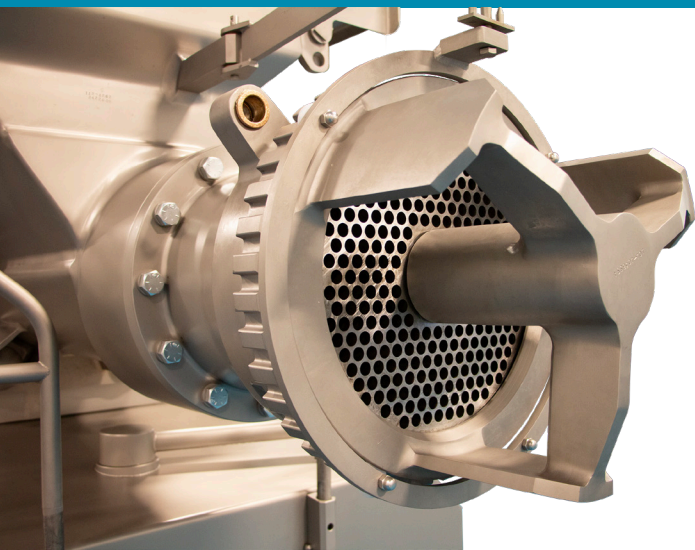

Specifications

GEARBOX	Mounted with heavy duty 16123-DOM epoxy coated gearbox
MOTOR	400 HP (300 kW)
ADJUSTABLE DISCHARGE HEIGHT	50" - 53" (1270 mm - 1346 mm)
ADJUSTABLE INLET HEIGHT	85" - 88" (2159 mm - 2335 mm)

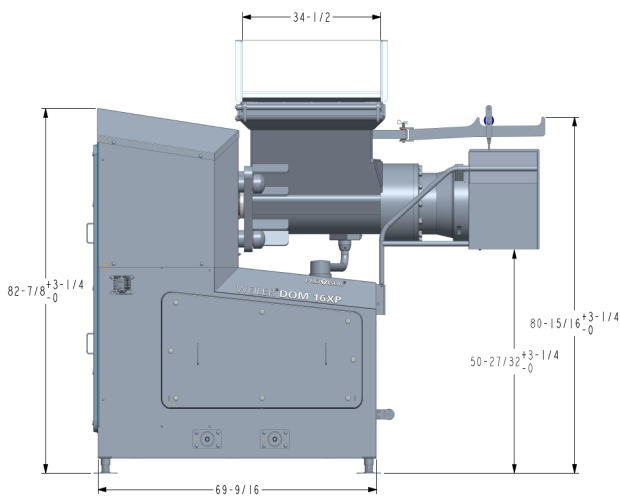

Side view

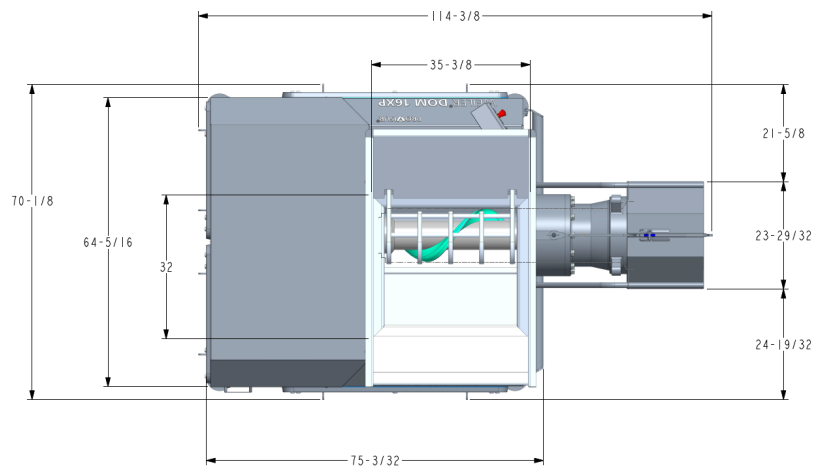

Top view